



**Chicago
Pneumatic**

CP9790C & CP9792C

3/8" KEY & 3/8" KEY LESS

**DRILL
Serie D**

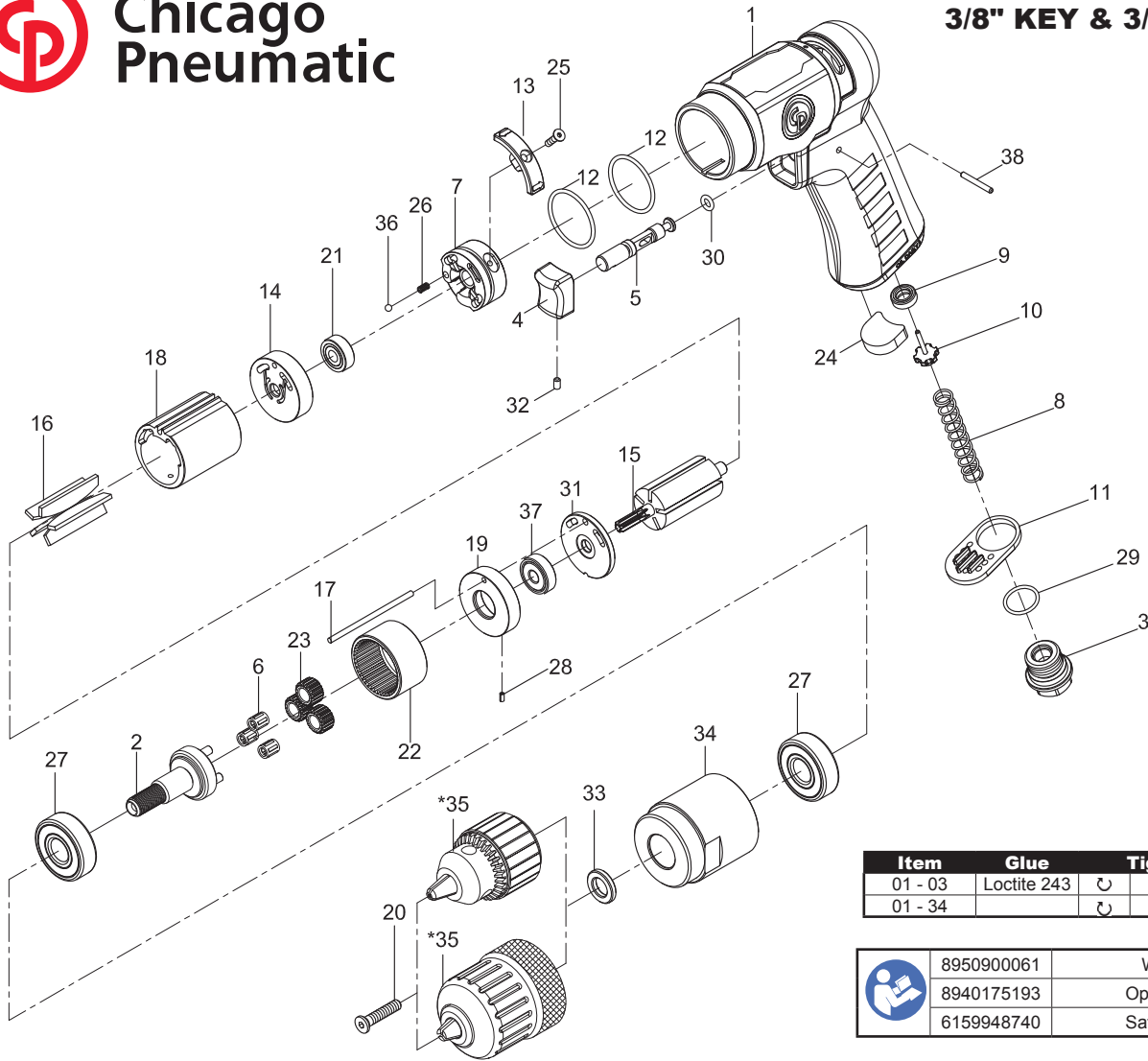

Item	Glue	Tightening torque
01 - 03	Loctite 243	7.3 ft.lb - 10 Nm
01 - 34		36.9 ft.lb - 50Nm

	8950900061	Warning Label
	8940175193	Operator's Manual
	6159948740	Safety Instructions

Ref	CP Part No.	Description	Q'ty
A	8940175265	Throttle Kit	1
8		Spring	1
9		Valve Seal	1
10		Valve	1
B	8940175266	Inlet Kit	1
3		Air Inlet	1
11		Silencer	1
29		O-Ring	1
C	8940175296	Motor Housing Kit	1
1	8940175234	Motor Housing with grip	1
4		Trigger	1
5		Valve Stem	1
30		O-Ring	1
32		Set Screw	1
38		Pin	1
D	8940175267	Trigger Kit	1
		Include 4,5,30,32,38	
E	8940175268	Regulator Kit	1
7		Distributor	1
12		O-Ring	2
13		Reversibility Button	1
25		Screw	1
26		Spring	1
36		Steel Ball (3mm)	1
F	8940175269	Rear End Plate	1
14		End Plate	1
21		Ball Bearing (626zz)	1

Ref	CP Part No.	Description	Q'ty
G	8940175270	Front Plate Kit	1
17		Pin	1
19		Front End Plate	1
28		Spring Pin	1
31		End Plate	1
37		Ball Bearing (626zz)	1
H	8940175271	Gearbox Kit	1
2		Work Spindle	1
6		Needle Bearing	3
22		Internal Gear	1
23		Planet Gear	3
I	8940175290	Service Gear Set	
		Include 6(x3) & 23(x3)	
SP	8940175272	Small Parts Kit	
		Include 3, 11, 13, 17, 20, 24, 26, 28, 32, 33,36 & 38	
TK	8940175273	Tune-Up Kit	
		Include 9,12 (x2),16 & 30	

15	2050485903	Rotor	1
16	2050485913	Rotor Blades (Set of 5)	1
18	2050485933	Cylinder	1
27	2050486953	Ball Bearing (6201Z)	2
34	2050485443	Clamp Nut	1
	2050486973	Industrial Key Chuck (3/8") & Key(Not Shown) For CP9790C	1
*35	2050502063	Industrial Keyless Chuck (3/8") For CP9792C	1

*Optional parts

Recommended Accessories



Protecto-lube Oil (for air lubrication)
CA149661 (4 oz - 0.12 l)
CA000046 (20 oz - 0.59 l)



Airoilene Oil (to clean motor parts)
P089507 (1 gal - 3.8 l)